

Channel Rack

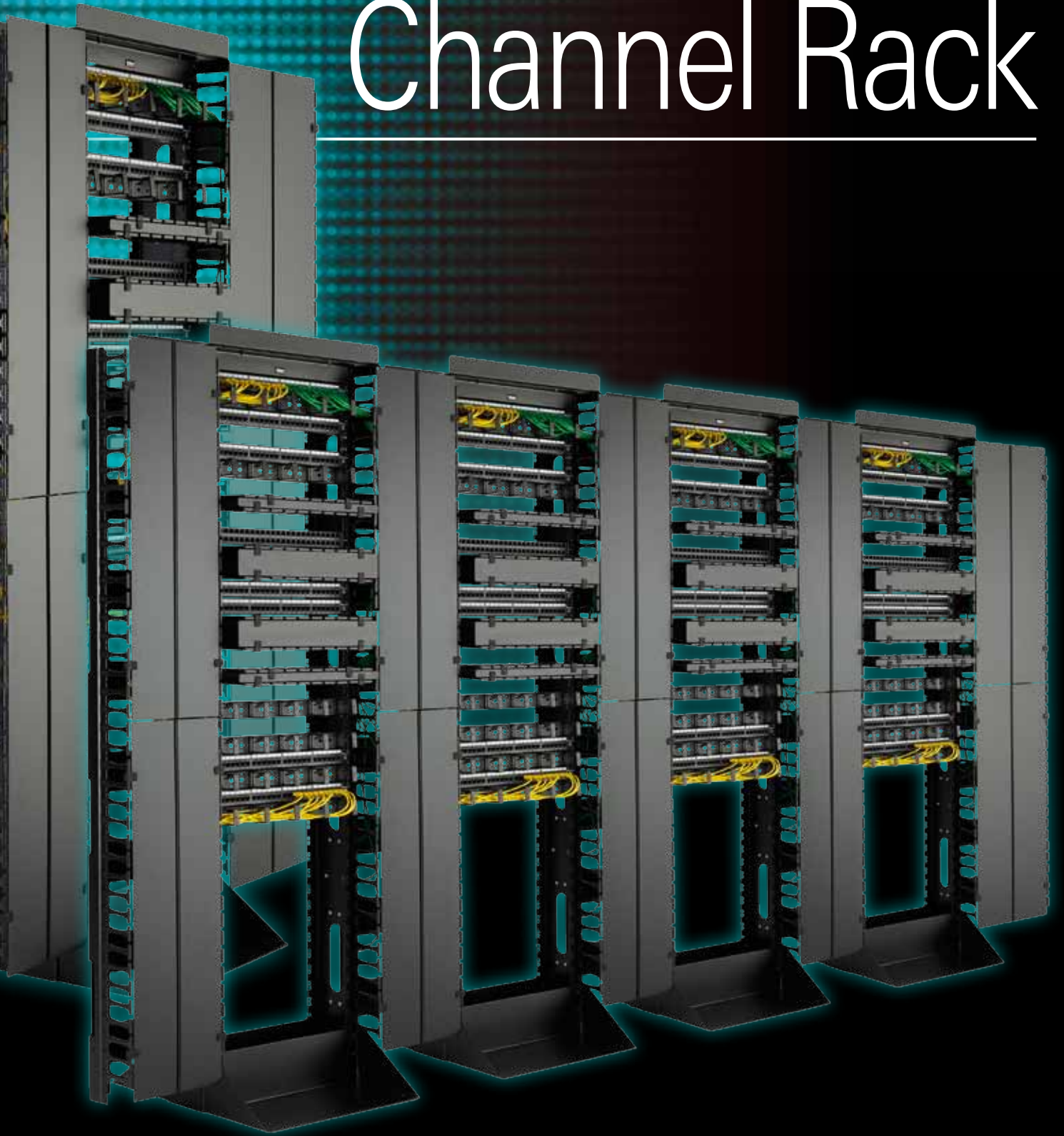

CHANNEL RACK COMPONENTS

FEATURES



Hallam Channel Racks provide an alternative, cost effective solution for the mounting of Patch Panels and Network Equipment when space and access is restricted.

Channel Racks are particularly useful for the mounting and storage of equipment in communications closets or secure rooms that do not necessarily facilitate the need for a fully enclosed cabinet or rack.

The Channel Rack comes to you fully assembled ready to install your equipment and additional cable management and accessory options.

A fully featured Pathfinder Cable Management option is simply added to one or both sides of the Channel Rack providing high density management of patch leads.

Applications

- High density patch lead management
- Cabling closets
- Data centres
- Network
- Communications
- Radio
- Telecommunications

Design

- Formed steel construction
- IEC 19" mounting – M6 caged nuts
- IEC 21" mounting – optional
- Two post and four post configurations
- 39RU and 45RU standard available heights
- Front and/or rear, single and/or double sided
"Pathfinder Cable Management"
- 3 x cable management channel widths

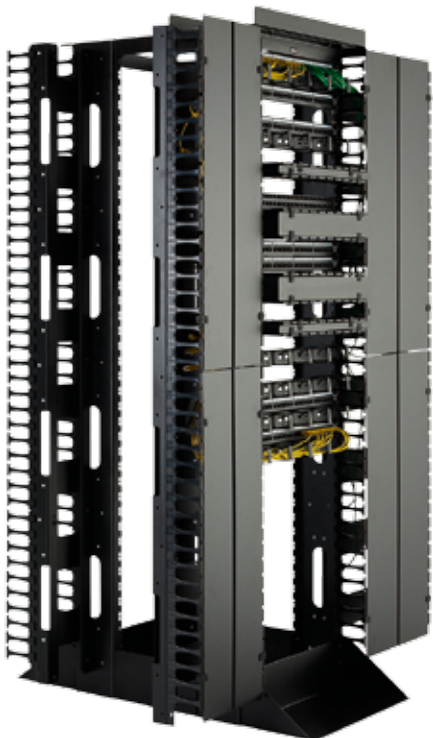

Channel Rack Components

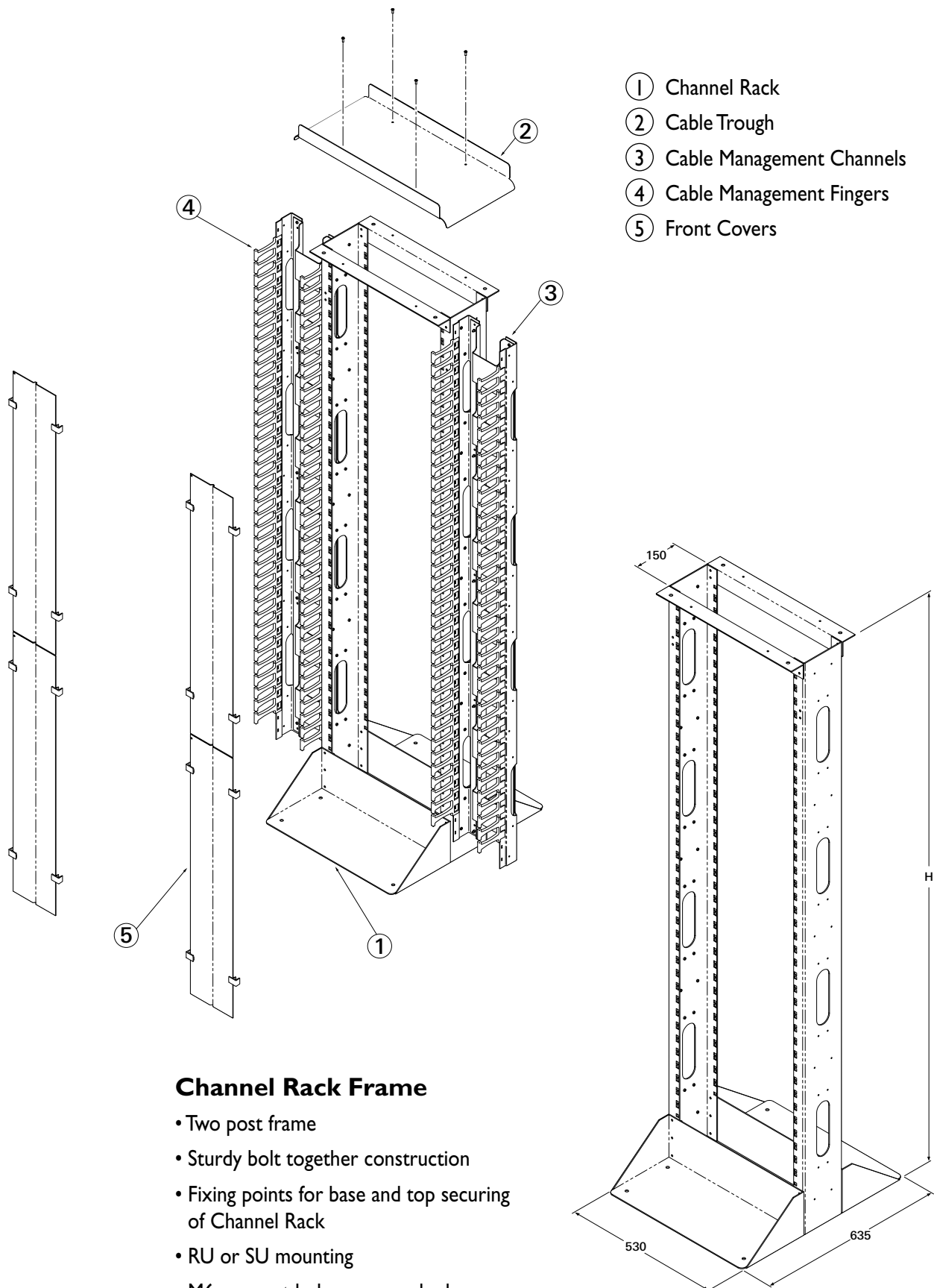

Channel Rack Components



Features

- Easy mounting of vertical power rails
- Highly durable powdercoat finish
- Extensive range of accessories
- Customised design and manufacture

RU	"H" – HEIGHT
18 (poa)	1002 mm
27 (poa)	1402 mm
39	1934 mm
45	2202 mm

CONFIGURING YOUR CHANNEL RACK FRAME

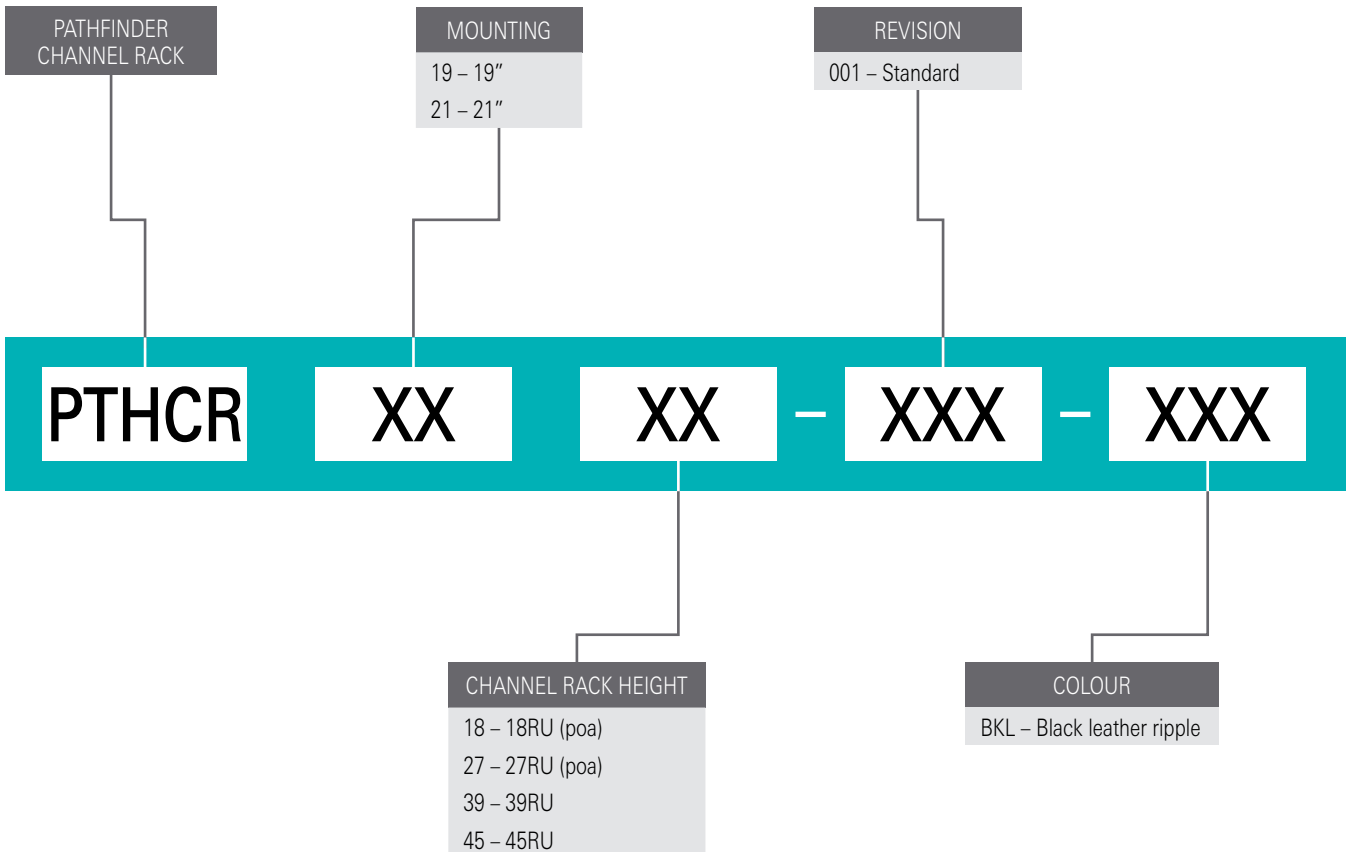

Four Post Channel Rack



Features

- Four post frame
- Stability and strength in an open frame environment
- Mounting of network, switch and routers in an open environment
- Multiple positions for Pathfinder Cable Management solution
- Optional depths between front and rear Channel Rack Sections
- Sturdy bolt together construction
- Fixing points for base and top securing
- Customised design and manufacture

CONFIGURING YOUR FOUR POST CHANNEL RACK

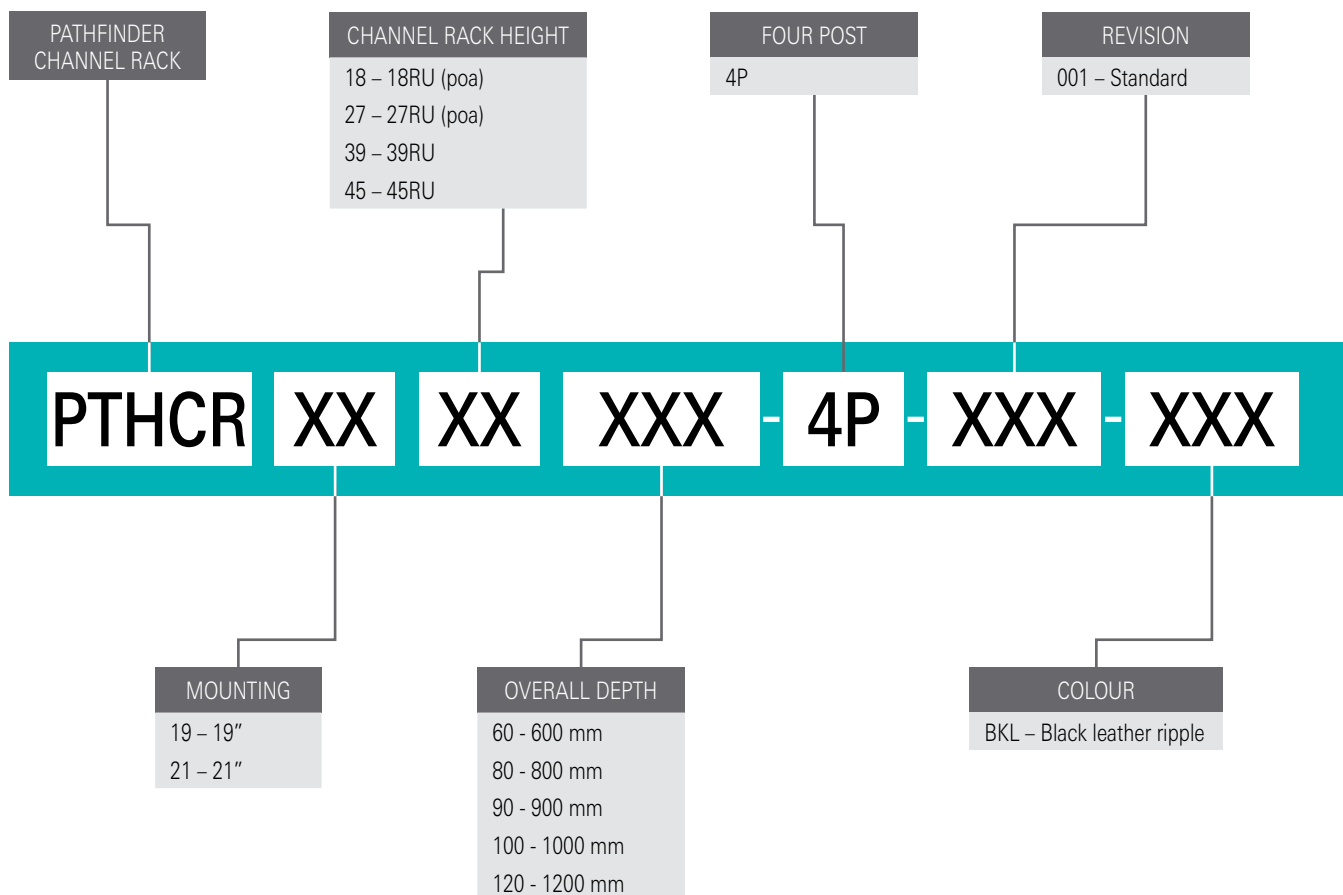

Channel Rack Cable Management



Features

- Management of patch leads/cable
- Strong lightweight aluminium construction
- Large cross sectional area for maximum cable capacities
- T shaped strong durable plastic cable fingers
- Cable fingers align with RU mountings
- Split metal covers – snap on/off or hinge
- 3 width options – 200mm, 300mm and 400mm
- Mounting of channels front and/or rear
- Mounting of cable spool managers – optional
- Durable powdercoat finish
- Customised design and manufacture

200 mm Double Sided

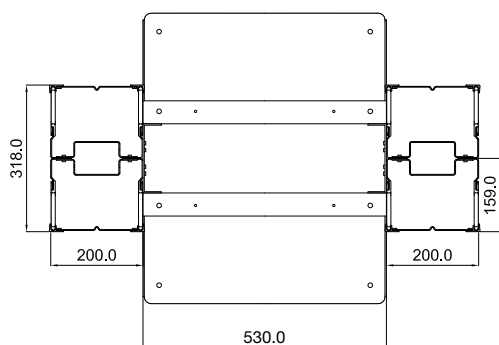

200 mm Single Sided

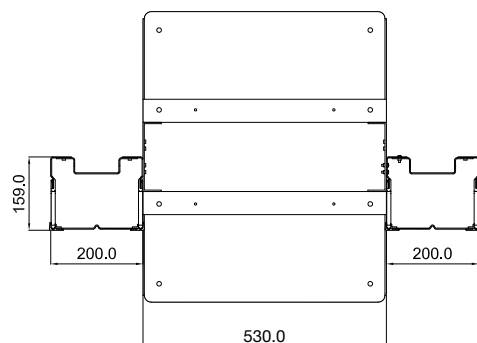

300 mm Double Sided

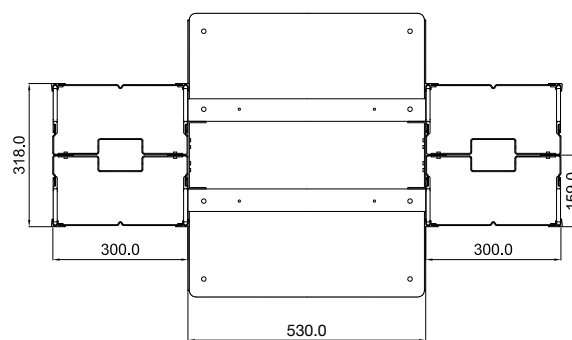

300 mm Single Sided

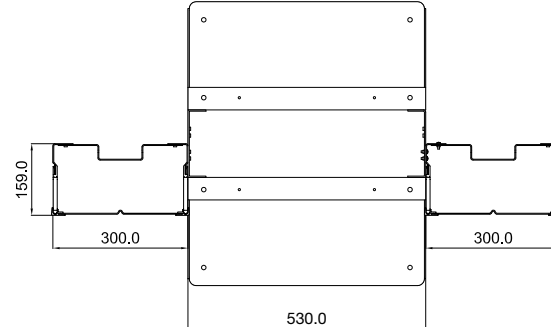

Channel Rack Cable Management

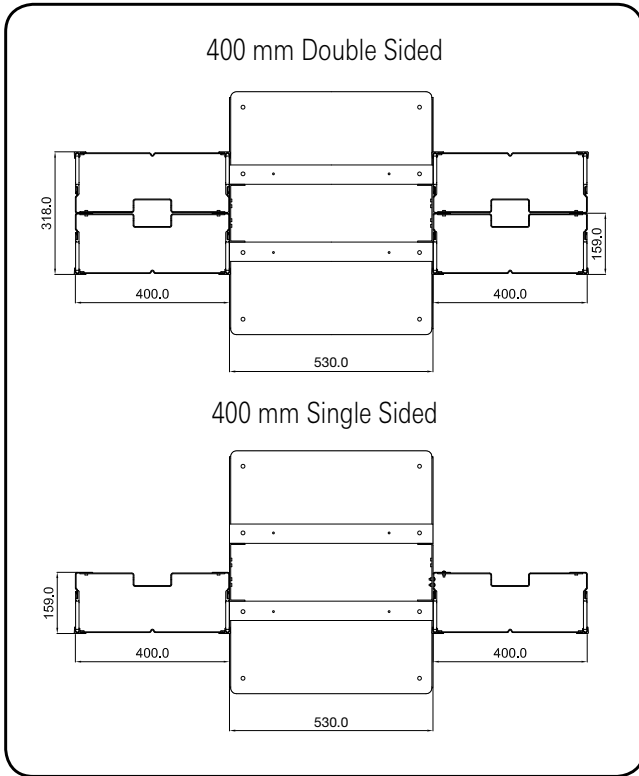

CONFIGURING YOUR CHANNEL RACK CABLE MANAGEMENT

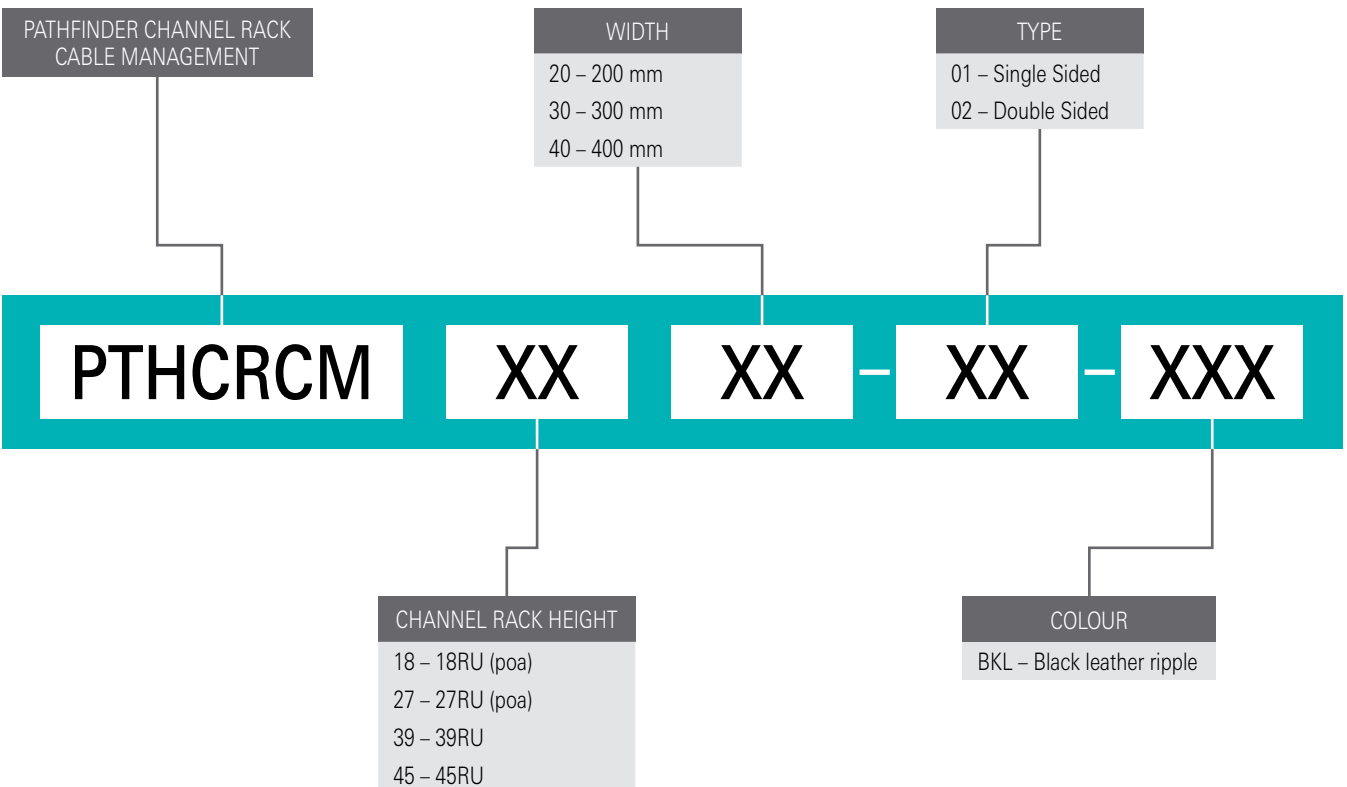

Channel Rack Components



Channel Rack Cable Spools Features

- Management of Patch Leads / Cable
- Strong spun metal construction
- Ready to mount onto Pathfinder Cable Management Channels
- Multiple mounting positions within channel
- Spool dia 62.5mm
- Durable Powdercoat finish
- **P/No. PTHCSS-01-BKL**

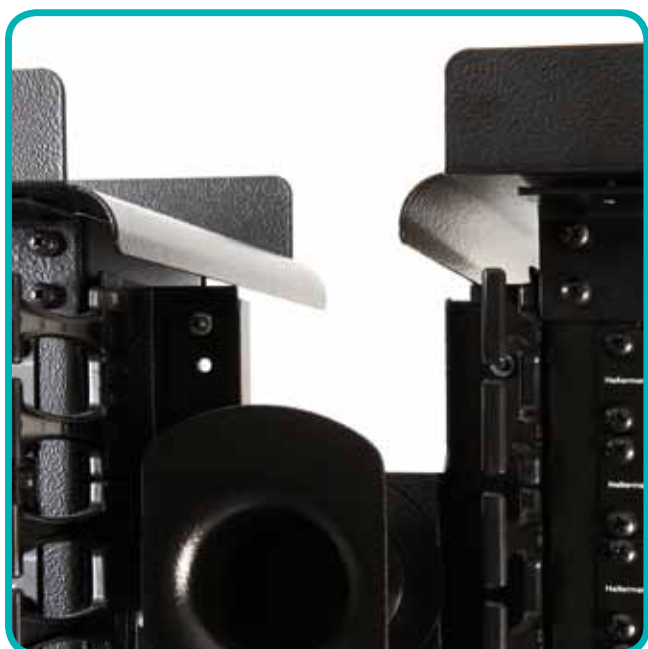

Channel Rack Cable Trough Features

- Management of multiple Patch Leads and Cable runs from one Channel Rack to another
- Strong lightweight aluminium construction
- Radius end drops to maintain cable bend radius
- Routing of cables into Pathfinder Channels
- Durable Powdercoat finish
- **P/No. PTHCRMCT-001-BKL**

How to Configure Your Channel Rack



To configure your Channel Rack follow the example shown below.

Configured components are expressed in examples below:

PTHCR Channel Rack	XX Mounting	XX Height	-	XXX Revision	-	XXX Colour
PTHCR Channel Rack	XX Mounting	XX Height	-	XXX Depth	4P 4 Post	XXX Depth
PTHCRM Cable Management	XX Height	XXX Width	-	XXX Type	-	XXX Colour